



O500RS 1836 Manual

DATA TEKNIS

MESIN & TRANSMISI

Mesin	Mercedes-Benz OM 457 LA Euro 3 Diesel, 6-Silinder Segaris, Injeksi Langsung dengan Turbo charger dan Intercooler
Total Isi Silinder	11.967 cc
Diameter / Langkah	128 / 155 mm
Daya Maksimum	260 kW (349hp) @ 2,000 rpm
Torsi Maksimum	1.600 Nm @ 1,100 rpm
Transmisi	MB GO 210 - 6 Transmisi 6 Percepatan Maju Dilengkapi dengan Primary Retarder
Perbandingan Gigi	6.528/3.711/2.231/1.443/1.000/0.799 Mundur = 6.136
Kecepatan Maksimum	120 km/jam
Daya Tanjak	48%

GANDAR

Depan (1st Axle)	MB VO 4/40 DCL - 7.1
Kapasitas	7,000 kg
Belakang	HO 4 / 08 DCL - 11.5
Perbandingan Gigi	3.333 (40:12)
Kapasitas	11,000 kg

SUSPENSI

Depan	Suspensi Udara dengan 2 Balon Udara, 4 Double Acting Shock Absorber
Belakang	Suspensi Udara dengan 4 Balon Udara, 4 Double Acting Shock Absorber
Fitur Tambahan	Pengaturan level suspensi secara Elektronik (ENR: Electronic Level Control System)

REM & KEMUDI

Rem Utama	Disc Brake, Dua Jalur Udara Tekan Penuh
Rem Parkir	Pegas, Kendali Udara Tekan Penuh Pada Gandar Belakang
Rem Tambahan	Retarder Voith 115, Digerakkan secara Elektro-Hidrolik Melalui Lever Pada Steering dengan 5 Step, Top Brake / Constant Throttle, Exhaust Brake
Fitur Tambahan	ABS (Anti-lock Braking System), ASR (Acceleration Skid System), Cruise Control
Kemudi	Kemudi Power Steering ZF 8098

BAN & PELEK

Ban	295 / 80 R 22.5
Pelek	8.25 x 22.5

KELISTRIKAN

Sistem	24 Volt
Alternator	28 V / 140 A (Terpasang) + 28 V / 140 A (Toolbox)
Baterai	2 x 200 Ah, 12 V

TANGKI BAHAN BAKAR

Kapasitas Tangki	300 Liter
------------------	-----------

UKURAN UTAMA

Jarak Sumbu	3,000 mm (Sasis) / 6,300 mm (Karoseri)
Julur Depan	2,570 mm
Julur Belakang	3,350 mm
Panjang Total	8,920 mm (Sasis) / 12,220 mm (Karoseri)
Lebar Total	2,458 mm
Jarak Pijak Roda Depan	2,036 mm
Jarak Pijak Roda Belakang	1,798 mm
Sudut Datang	13.41°
Sudut Pergi	8°
Radius Putar	10,460 mm
Berat Sasis	6,920 kg
Berat Kotor Kendaraan (GVW)	18,000 kg

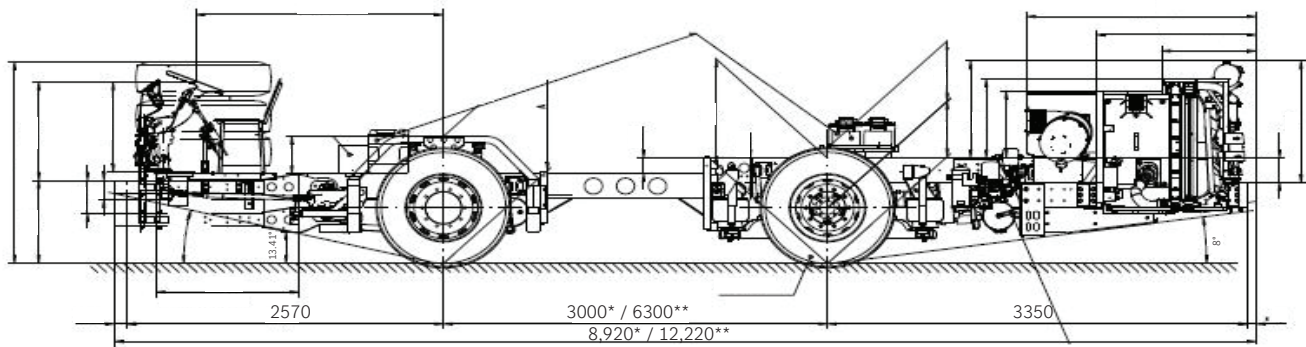

Tampak Samping

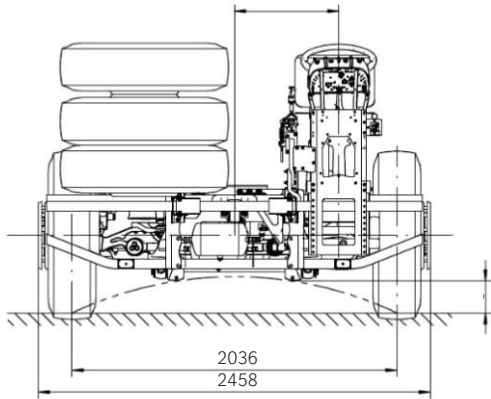

Tampak Depan

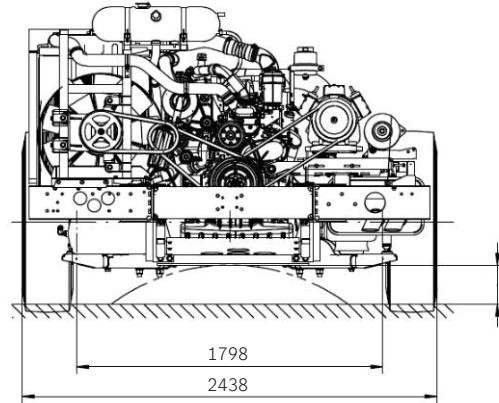

Tampak Belakang

Keterangan: * Sasis
** Karoseri

Bus Warranty Package.

Worry less while you make more, Mercedes-Benz Bus come with a Bus Warranty Package as a standard. The warranty entitles you with:

- Overall Vehicle Warranty: 12 months / 50,000km from delivery (whichever come first after the first 12 months following initial registration).
- Powertrain Warranty: 24 months / 100,000km from delivery (whichever come first after the first 12 months following initial registration).
(except: Wear and Tear Part)

Our Authorized Mercedes-Benz Commercial Vehicles Dealers ensure your vehicles with service that you can trust. Every regular service, maintenance and repair are carried out by professionally trained and certified technicians using original Mercedes-Benz spare parts only.

Visit our Authorized Mercedes-Benz Commercial Vehicles Dealers at any time for more details. Our highly dedicated trained team, complete tools and sophisticated diagnostic equipment are at your service.

PT Kalimas AI - Yogyakarta:

Jl. Raya Yogya – Solo Km. 9 Yogyakarta – 55010
Telp.: (0274) 488130, 484213, 488916

PT Kalimas AI - Semarang:

Jl. Raya Semarang – Demak Km. 7, Kota Semarang - 50118
Telp.: +62-(24)-6592-811
WA: +62-895-3911-63388

Daimler Commercial Vehicles Indonesia berhak mengubah konfigurasi produk tanpa pemberitahuan terlebih dahulu. Perubahan pada produk dapat terjadi sejak brosur ini dicetak (02.22). Foto produk pada brosur ini dapat berbeda dari produk-produk yang masuk ke Indonesia. Untuk konfirmasi lebih lanjut, silahkan hubungi Authorized Mercedes-Benz Commercial Vehicles Dealers Anda.



and Mercedes-Benz are trademarks of Mercedes-Benz Group AG.

kalimas.net

instagram.com/mercedessemarang

youtube.com/@kalimasarubindonesia8866

facebook.com/kalimas.ai.7

